

Installation Instructions

For The Fuel Level Sender Kit P/N 226 008

SIEMENS VDO

A u t o m o t i v e

0 515 010 190

THE INSTRUCTIONS FOR THE INSTALLATION OF THE BASIC FUEL SENDER KIT FOLLOW. USE IS RESTRICTED TO 12 VOLT NEGATIVE GROUND ELECTRICAL SYSTEMS. FOR WIRING INSTRUCTIONS, REFER TO THE FUEL GAUGE INSTRUCTIONS.

Parts List

Item	Description	Quantity
1.	Fuel Level Sender	1
2.	Float Arm	1
3.	Gasket and Hardware Kit	1

Additional Material Possibly Required To Complete Installation:

Weld-on installation kit (optional) P/N 226 901
Bolt-on installation kit (optional) P/N 226 451

CAUTION: Read these instructions thoroughly before making installation. Do not deviate from assembly or wiring instructions. Always disconnect positive battery lead before making any electrical connections. If in doubt, please contact your dealer or VDO Instruments at **1-800-265-1818**

Fuel Level Sender Installation

The Fuel Level Sender has a resistance rating of 0 ohms when the tank is empty and 90 ohms when full. Refer to the VDO-Yazaki catalog for matching fuel gauges. The unit can be adjusted to read accurately in tanks from 6" to 23" deep. For sender adjustment, refer to Table 1 and Fig. 2.

I. Measure depth of the fuel tank. Locate this dimension in Column "A" of Table 1. Column "B" then shows the length from the underside of the sender flange to the center of the float pivot. Column "C" shows the distance from the center of the float pivot to the center of the float ball. For example, a tank 12" deep would need a measurement of 6" from the flange to the pivot, and 7.8" from the pivot to the float.

II. For tank depths up to 15-1/2" it will be necessary to eliminate a part of the assembly. (See Fig. 1) Proceed as follows:

1. Remove nut "a", washer "b", and ring terminal "c" from the underside of the mounting flange.
2. Remove two screws "d" and discard.
3. Remove two screws "e" from the plastic housing and reserve for later use.
4. Carefully remove bracket "f" from the plastic housing and discard. Replace with bracket "g" in the housing and loosely re-install the two screws "e" into housing.
5. Slide housing up or down until the proper dimension from Table 1 is reached, then tighten screws securely.
6. Replace ring terminal and hardware.

CAUTION: Do not overtighten hardware, to avoid damage to the threads.

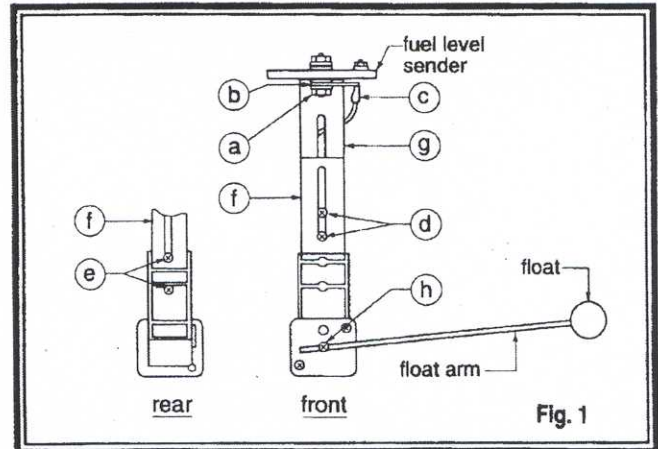

CAUTION: When installing the float arm into the sender body, make sure the float ball is to the right side when you face the unit, as shown in Fig. 1. If installed to the left, the fuel gauge will read "full" when the tank is empty.

III. For tank depths of 16" to 23", no disassembly of the sender bracket is necessary.

1. Remove ring terminal as instructed in Section II, above.
2. Loosen two screws "d" and adjust the plastic housing up or down until the proper dimension from Table 1 is obtained, then retighten screws securely.
3. Re-install ring terminal and hardware, and tighten all hardware securely, avoiding overtightening.

IV. To install the float assembly, loosen screw "h", remove the short piece of rod, and discard. Insert the float rod until the proper length "c" from Table 1 is met, then tighten the screw securely. Carefully cut off any excess rod with a bolt cutter or similar tool, taking care not to damage the assembly.

NOTE: Make sure the float is installed as shown in Fig. 1. If installed backwards, the fuel gauge will indicate "full" when the tank is empty, and "empty" when the tank is full.

VDO Instruments recommends that the fuel sender and the fuel gauge be wired together and checked for compatibility prior to installing fuel sender into tank.

SAFETY PRECAUTION: When making modifications to fuel tanks, it is essential that the tank be removed from the vehicle, and that it is empty, clean, and dry. After drilling, make sure all chips and other foreign matter have been removed from the tank.

V. Refer to Fig. 3 for installation of the fuel sender assembly into the tank. The sender flange is designed to fit a standard SAE hole pattern.

CAUTION: Before drilling any holes into tank, place the sender assembly on top of the tank to judge proper hole placement allowing float arm clearance inside of tank.

If no holes exist in the fuel tank (see CAUTION above):

1. Cut a 1.697" (43mm) hole in the top of the tank.
2. With the gasket in place below the flange, carefully feed the float arm and sender body into the 1.697" (43mm) hole in the tank. Make certain the float arm has free motion within the tank. Using the sender flange as a template, locate the positions of the five mounting holes. Depending on the thickness of the tank, either self-tapping screws or #8-32 machine screws may be used, drilling and tapping accordingly. If threaded holes already exist, check the thread size and use the appropriate hardware.

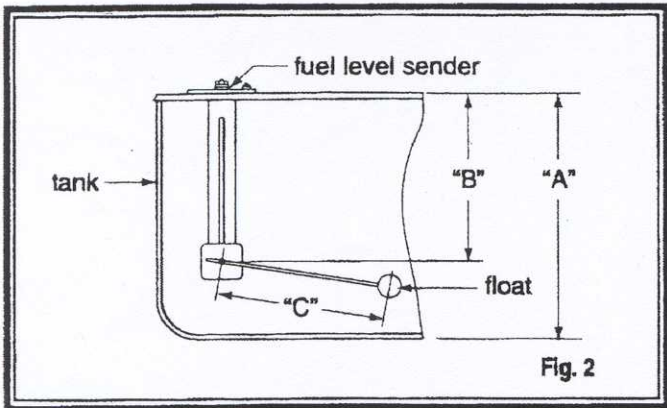

Fig. 2

TABLE I (dimensions in inches)								
A	B	C	A	B	C	A	B	C
6.0	3.0	3.5	12.0	6.0	7.8	18.0	9.0	12.0
6.5	3.25	3.8	12.5	6.25	8.1	18.5	9.25	12.3
7.0	3.5	4.2	13.0	6.5	8.5	19.0	9.5	12.6
7.5	3.75	4.5	13.5	6.75	8.9	19.5	9.75	12.9
8.0	4.0	4.9	14.0	7.0	9.3	20.0	10.0	13.4
8.5	4.25	5.3	14.5	7.25	9.6	20.5	10.25	13.8
9.0	4.5	5.6	15.0	7.5	10.0	21.0	10.5	14.2
9.5	4.75	6.0	15.5	7.75	10.4	21.5	10.75	14.6
10.0	5.0	6.4	16.0	8.0	10.7	22.0	11.0	15.0
10.5	5.25	6.7	16.5	8.25	11.0	22.5	11.25	15.4
11.0	5.5	7.1	17.0	8.5	11.4	23.0	11.5	15.7
11.5	5.75	7.4	17.5	8.75	11.8			

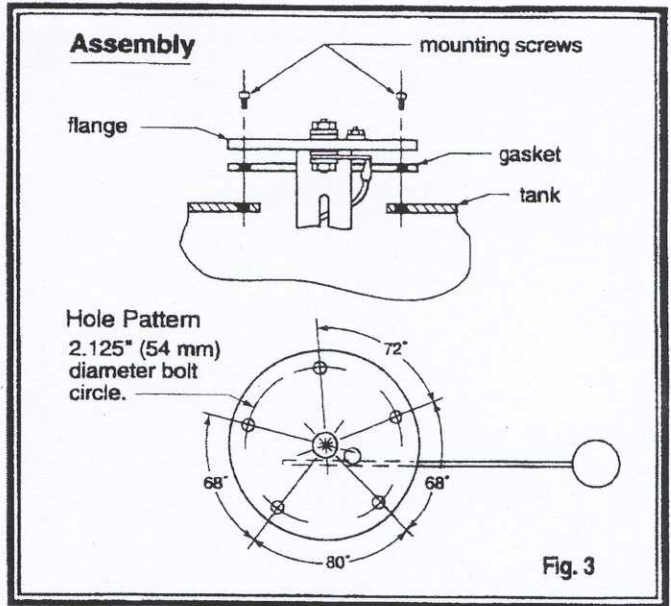

Fig. 3

3. Insert fuel sender assembly into tank, align holes and thread in 1/2" mounting screws, through holes in sender flange and tank. Check that all screws are secure to complete assembly. AVOID OVERTIGHTENING.

VDO Instruments gauges are repairable.

VDO Limited Warranty

VDO-Yazaki Corporation warrants all merchandise against defects in factory workmanship and materials for a period of 24 months after purchase. This warranty applies to the first retail purchaser and covers only those products exposed to normal use or service. Provisions of this warranty shall not apply to a VDO product used for a purpose for which it is not designed, or which has been altered in any way that would be detrimental to the performance or life of the product, or misapplication, misuse, negligence or accident. On any part or product found to be defective after examination by VDO-Yazaki Corporation, VDO-Yazaki Corporation will only repair or replace the merchandise through the original selling dealer or on a direct basis. VDO-Yazaki Corporation assumes no responsibility for diagnosis, removal and/or installation labor, loss of vehicle use, loss of time, inconvenience or any other consequential expenses. The warranties herein are in lieu of any other expressed or implied warranties, including any implied warranty of merchantability or fitness, and any other obligation on the part of VDO-Yazaki Corporation, or selling dealer. (NOTE: This is a "Limited Warranty" as defined by the Magnuson-Moss Warranty Act of 1975.)